

2019 SUNY TYESA Mini UAV Competition

Friday, May 3, 2019

Monroe Community College, Rochester NY

Project

Teams of sophomore and freshman students will design, build, and pilot a mini Unmanned Aerial Vehicle (UAV) to transport a rescue kit through a series of obstacles and return to the starting point. The UAV must be able to maneuver around and through obstacles, change altitude and carry/deposit a payload to the proper drop zone, then navigate back to the starting zone. This project is designed to simulate a rescue kit delivery where human navigation is difficult or dangerous.

Project requirements

The UAV must pass all given specifications: dimensions, cost, and part constraints. Participants cannot purchase and modify an existing commercially available vehicle. Participants can purchase individual components: a frame kit, propulsion, and control system for their UAV.

Participants are encouraged to engage in research and design a frame for their UAV. It is expected that participants will become adept to line of sight piloting in preparation for the competition.

Time and Location

The competition will be held in the *PAC Field House* at Monroe Community College - Brighton Campus on Friday, May 3, 2019 at 9:00 AM. Participants should arrive and register at 9:00 AM. Directions to MCC can be found here: <http://www.monroecc.edu/depts/webmaps/>

Participating teams should report to Christopher Kumar at the MCC Engineering Department by Friday, April 5, 2019.

Christopher Kumar, *SUNY TYESA Treasurer*
Engineering Science and Physics Dept., *Chairman*
Monroe Community College
1000 East Henrietta Road
Rochester, NY 14623-5780
Phone: (585)292-2001; (585)292-2671
Email: ckumar@monroecc.edu

Vehicle Requirements

- *Budget:* The UAV budget must not exceed \$250 (excluding tax and shipping). The cost of materials for the frame and RC transmitter/receiver are not included in the \$250 budget. The \$250 limit affects all other components on the UAV. If over budget, there is a one-time 250 point penalty.
- *Power System:* The vehicle must be powered by battery; exotic fuels/battery will not be allowed.
- *Physical Properties:* The purchase and modification of commercially available vehicles is prohibited. Off-the-shelf frame kits are not permitted; teams must engage in research and design a frame for their small UAV. The fully assembled small UAV (Propellers included) must be capable of fitting in a 24 x 24 x 12 inch box.
- *Manual Flight:* The piloting of the small UAV must be solely controlled by a wireless RC transmitter/receiver link. No other contact, interaction or influence is permitted. During the competition, during a team's run, all other team's RC transmitters/receivers should be off. Pilots are allowed to move around while the small UAV is in flight.
- *Flight Termination:* The aircraft must have a preflight safety switch and a mid-flight shut-off switch. The preflight safety switch allows you to handle your aircraft safely by disabling the motors until you activate the switch. The mid-flight shut-off switch allows you to disable motors mid-flight, in the event that the small UAV becomes unstable and/or unsafe. If a small UAV is deemed unsafe during flight, judges will require that pilots hit the mid-flight shut-off switch.
- All vehicles must adhere to the part specifications outlined on page 9 (Appendix B). It is acceptable for a team to purchase a part from different vendor and/or brand name as long as it agrees with the provided specifications. A brief bill of materials must be included for each UAV. The bill of materials needs only to provide for parts included in the parts table below. Note: teams must follow the exact part order list or there is a one-time 50 point penalty.

Competition Scoring

There are two major elements of the competition: the mission demonstration and the poster presentation. They are worth 80% and 20% respectively of the overall scoring points.

Part I: Mission Demonstration (80%)

Part II: Poster Presentation (20%)

Part I: Mission Demonstration (80%)

Course Description: The rectangular course of 16 ft. by 26 ft. will consist of a flat, level section of field marked off with masking tape, and the corresponding airspace will be above the field. The course contains a starting platform, a payload delivery tower, a secondary payload delivery net stand, and two obstacle gates. The location of the gates/tower will be randomized, and will maintain a minimum distance of 6 ½ ft. from each other. The payload delivery I-light source tower will have a height of 36 inches, The payload delivery II-net stand will have a height of 84 inches (7 ft) and the starting platform will have a height of 4 inches (figure 1- 4).

Flight Sequence: The team's pilot must navigate the small UAV through the course in the following sequence. Upon leaving the starting platform, the UAV must fly through the first designated gate, then through the second designated gate. Then the UAV must deliver the payloads to their designated payload

delivery sights. Once completed, the UAV must fly through the gates in reverse order in which it initially traveled and land safely on the starting platform. The total time allotted for the flight sequence will be 240 seconds, and the team will receive 240 (Trial time in seconds) points.

Obstacle Gates: The small UAV must fly through the window opening of the gate. 100 points will be awarded each time the UAV passes through a gate. This may only be done once per gate before and once per gate after the payload delivery for a total of 400 points maximum per trial. If the small UAV hits the gate, the team will not gain any points for that gate attempt; instead, they will lose 100 points.

Payload Delivery I: The payload is a fragile object with approximately 60 mm in diameter and weighs under 60 grams (large size egg). The payload will be loaded onto the team's UAV before the mission begins. The platform of the 12 inch high payload delivery-light source tower will be colored red. In addition, the tower will be equipped with a matching high intensity LED ring and conically focused laser arranged to point vertically in the center of the platform. The tower platform will be framed and it will be 36 inches high. Once the pilot has navigated the UAV to a payload delivery platform, the small UAV must autonomously determine when to release the payload onto the platform. The fragile object must be released onto the red platform. The team will be awarded 200 points for successful payload delivery. A successful payload delivery requires that there is absolutely no damage to the payload. If the payload is damaged, no points will be awarded.

Payload Delivery II: The payload will be a small spherical object with a diameter of approximately 40mm and a weight of approximately 3 grams (Ping-Pong ball). The payload will be loaded onto the team's UAV before the mission begins. The intended target is a net standing 84 inches (7ft) high with a circular diameter of 34 inches. Once the pilot has navigated to their desired delivery location, the pilot must manually launch the payload into the net from within the course boundaries. The team will be awarded 200 points for successfully delivering the payload into the net.

Part II: Poster Presentation (20%)

Prior to the mini UAV competition, each team must participate in the poster presentation session, where each participating team will exhibit and present their UAV project to the event attendees, spectators, and judges. During the exhibition period, judges will visit each participating team and request a poster presentation. This will be followed by questions. This process will take approximately 5 to 7 minutes per team. The entire poster presentation session is scheduled to last approximately 90 minutes; however, this may change depending on the number of participating teams.

The poster presentation will occur on Friday, May 3, 2019 at 9:00 am in the MCC PAC Field House the same day as the mini UAV competition. All the team members must be present for the entire poster presentation period along with their UAV. Teams may use laminated posters, written documents, physical prototypes, multimedia displays, and other visual aids at their booths. Each team will be provided with a table and tripod.

Judges will score on the following categories: Design Evolution, Mechanical Analysis, Electrical Analysis, software Analysis, and Exhibit Quality. They will score on a scale of 0 to 10 (10 being the best) for each category. The score will be calculated by deleting the highest and lowest scores from the judges and averaging the remaining scores (dividing by 5).

Note: teams must include cad dimensions of major components (propellers, motors, frame, flight controller, etc.) and overall design of the assembled UAV. Motor and propeller selection must be briefly explained, along with calculation for thrust and maximum payload lift.

The final score will be the sum of scores from the three trials, including any broken rule deductions, bonuses and presentation scores.

Example Trial:

Instructions

- All teams must report before the competition begins.
- The UAV size will be measured. If the size is exceeded, judges may disqualify the team from the competition or may give a severe penalty.
- Team members must inspect the course and location of the payload before the judges signal to start the trial. Once the trial has commenced, the run counts as an official run. There is no redo.
- If a UAV fails to operate after the judges have given the start command, the team members may work on their UAV to get it moving but the time will continue to count from the time when the start command was given. If the time exceeds 240 seconds of the start command, a score of zero will be assigned for that trial.
- The UAV must start from the starting platform; maneuver through two obstacle gates, then deposit both payloads into their designated locations and return to the starting point by passing obstacle gates again. There will be no penalty for maneuvering outside the bounds of the defined course area.

Note: All pilots must fly on a line of sight basis. No First Person View (FPV) cameras may be used to navigate.

Score

Mission Trial	Trial 1	Points	Trial 2	Points	Trial 3	Points
Successful Gates	100*3	+300	100*4	+400	100*2	+200
Unsuccessful Gates	100*1	-100	100*0	0	100*2	-200
Time Trial	240-90	+150	240-60	+180	240-100	+140
Payload Delivery I	200*1	+200	200*1	+200	200*1	+200
Payload Delivery II	200*1	+200	200*1	+200	200*1	+200
Total	-	750	-	980	-	540
Maximum Possible Score	-	1040	-	1040	-	1040
Total % for Each Trial		72.1%		94.2%		51.9%
The average of the 3 trials	72.8%					
Mission Demonstration (80%)	72.8% of Mission Demonstration total (80%) is 58.21%					
Poster Presentation (20%)	16.4% (see table below)					
Competition Total	58.21% + 16.4% = 74.61%					

Poster Presentation	Points
Design Evolution	8.0
Mechanical Analysis	9.0
Electrical Analysis	10.0
Software Analysis	7.0
Exhibit Quality	7.0
Total	8.2%
Poster Presentation (20%)	16.4%

Note: On the competition day, designated judges will interpret the rules and determine all decisions. The decision will be final and will not be negotiable. All teams must respect the decision. The purpose of this competition is to support students' interest in mathematics, engineering, science, and technology. We expect the competition to be a learning environment, and to be cordial and courteous.

Appendix A: Schematics of course, obstacle gates, starting platform and payload delivery-light source towers

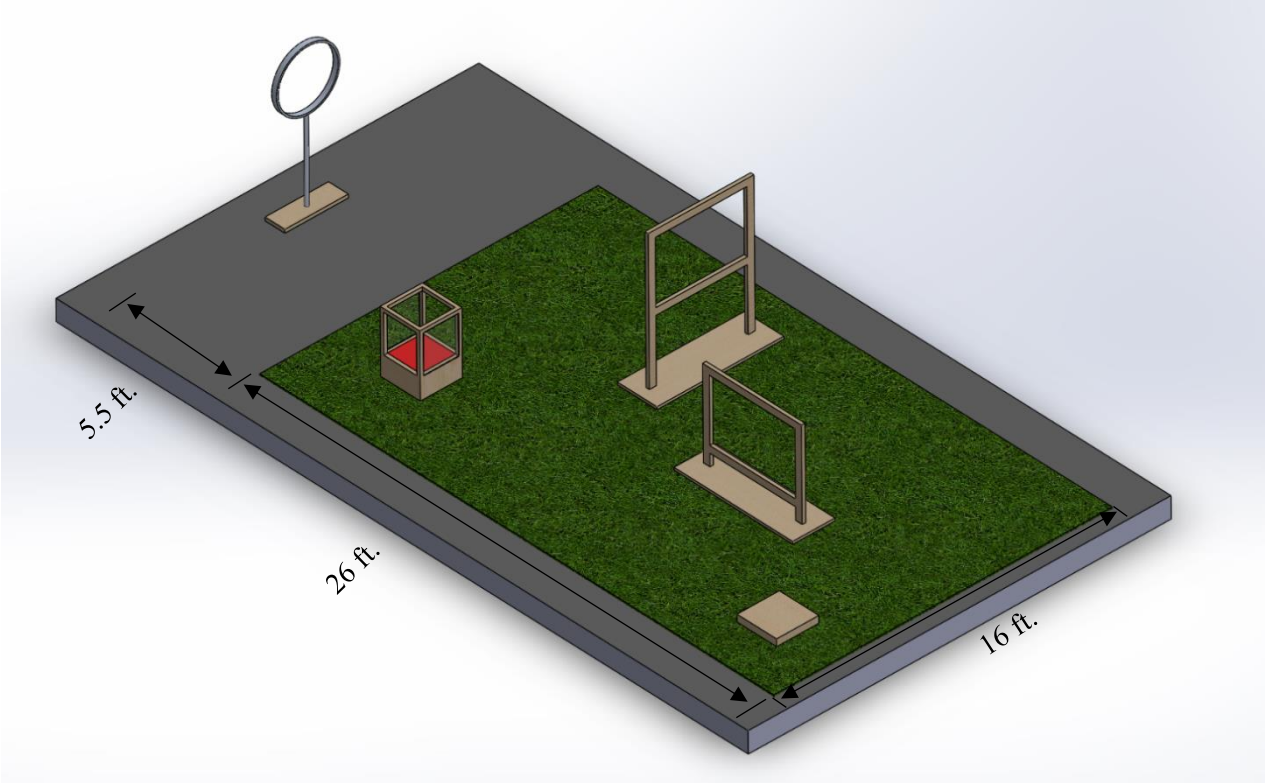

Figure 1: The isometric view of the course constructed in the indoor field house.

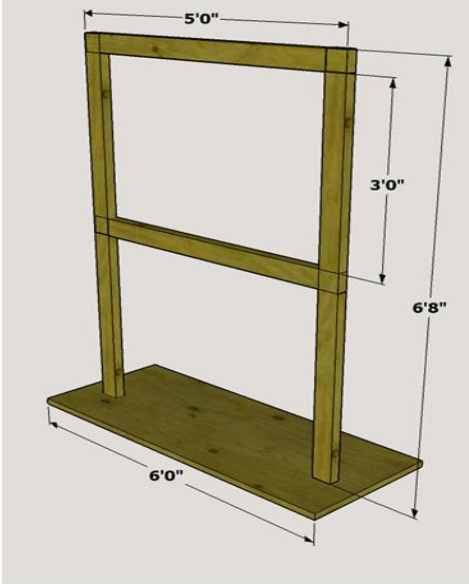
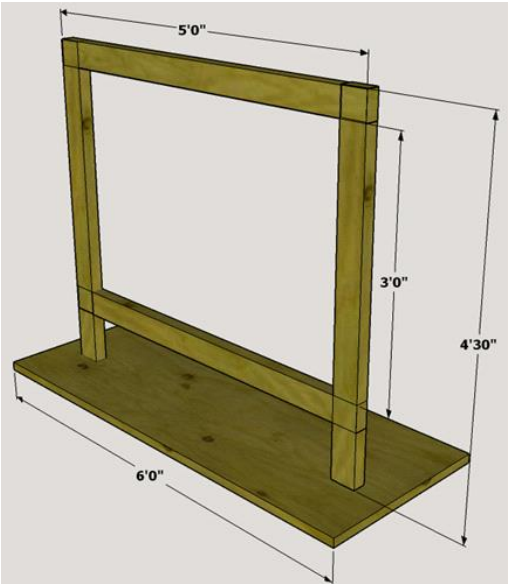

Figure 2: Schematics for obstacle lower gate and higher gate. Each gate will be 5 ft. wide with a 3 ft. tall opening.

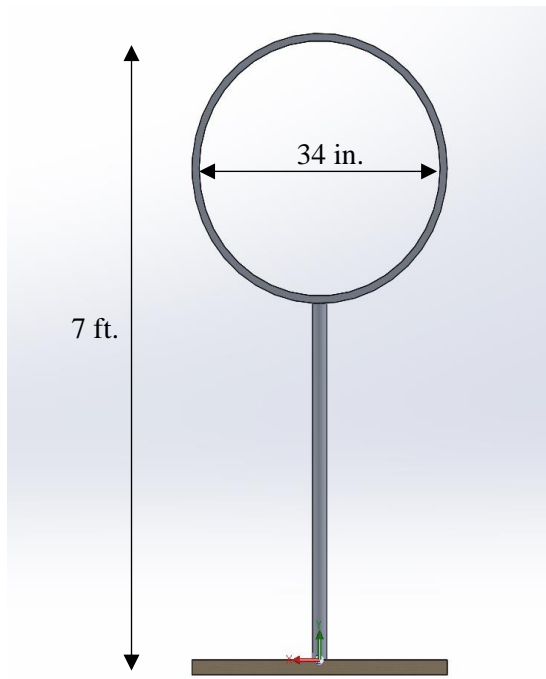
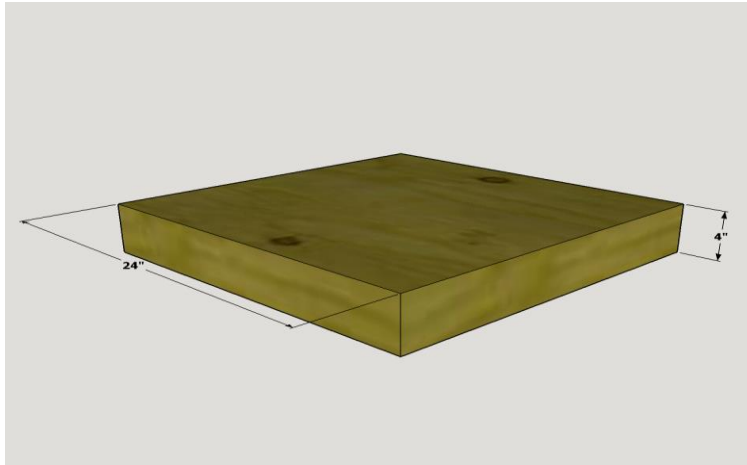

Figure 3: Schematic for starting platform (24" x 24" x 4") and payload delivery net. The net will stand 7 ft. high with a circular diameter of approximately 34 in.

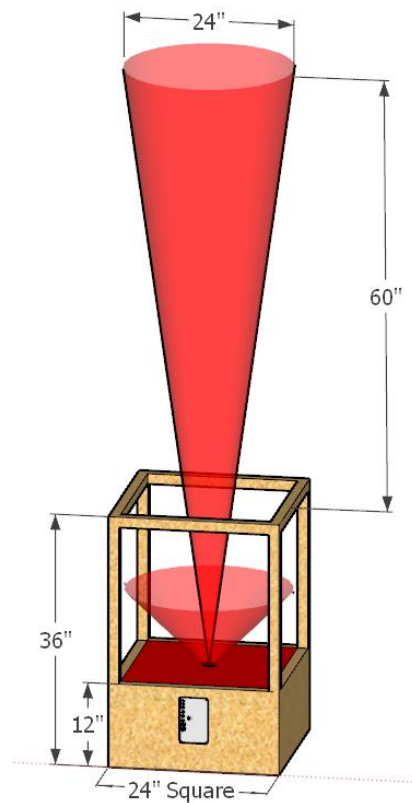

Figure 4: Profile view of payload delivery-light source towers & light cone dimensions determined using the TCS230. The schematic for payload delivery-light source towers is 24" x 24" x 36".